

Fox

borg &
overström

Distinctive
by design.

Elevate the hospitality
experience

... with a
premium tap system



www.foxtrading.co.uk



c2
c3
t2

Fox

borg &
overström

Distinctive
by design.



www.foxtrading.co.uk

C2
C3

Fox

borg &
overström

High-capacity output

These tap systems bring high-capacity refreshment to any commercial environment. Combining elegance with performance, this water dispenser meets demand every time. A simple pull of the chrome faucet provides thirst-quenching ambient, chilled, or sparkling water.



C2 twin head tap system

C3 triple head tap system

Distinctive
by design.

C2
C3



borg &
overström

A durable performer

Designed for endurance, the fine engineering and quality construction ensures dependable performance at all times. It delivers an impressive throughput of 80 litres per hour at a consistent chilled temperature, making it the perfect solution for busy environments.

Simple to operate and maintain

These innovative tap systems bring a high-capacity refreshment solution to any commercial venture. Available as a two-tap or three-tap system, it's intuitive to use and requires minimal maintenance. Simplicity in execution.

Versatile drip tray options

Integrated or freestanding stainless steel drip trays can be added to your tap system. Stainless steel is the perfect material match for water cooler dispensers. Unlike ordinary carbon or alloy steels, it won't ever corrode or rust. The integrated tray is compatible with the Alarmed Waste Kit for added convenience.

Compact ProCore™ processor

Our premium tap systems include an ultra-compact ProCore™ unit which fits discreetly into any space. It's also low maintenance and fitted with the new eco R290 gas. The colour-coated GreenCoat® steel construction makes it sustainable and durable.

Advanced UV protection built-in

As an option, the ProCore™ can be fitted with Viovandi™, a mercury-free and chemical-free UV water disinfection system. For complete peace of mind it also includes additional hygiene features via Borg & Overström's Totality® methodology.

Performance-enhancing ventilation

A discreet, compact ventilation kit is included with this system allowing a continuous cycle of cool air. Designed to be fast and easy to install, the Simple-Fit Ventilation Base enables the ProCore™ processor to run at optimum performance.

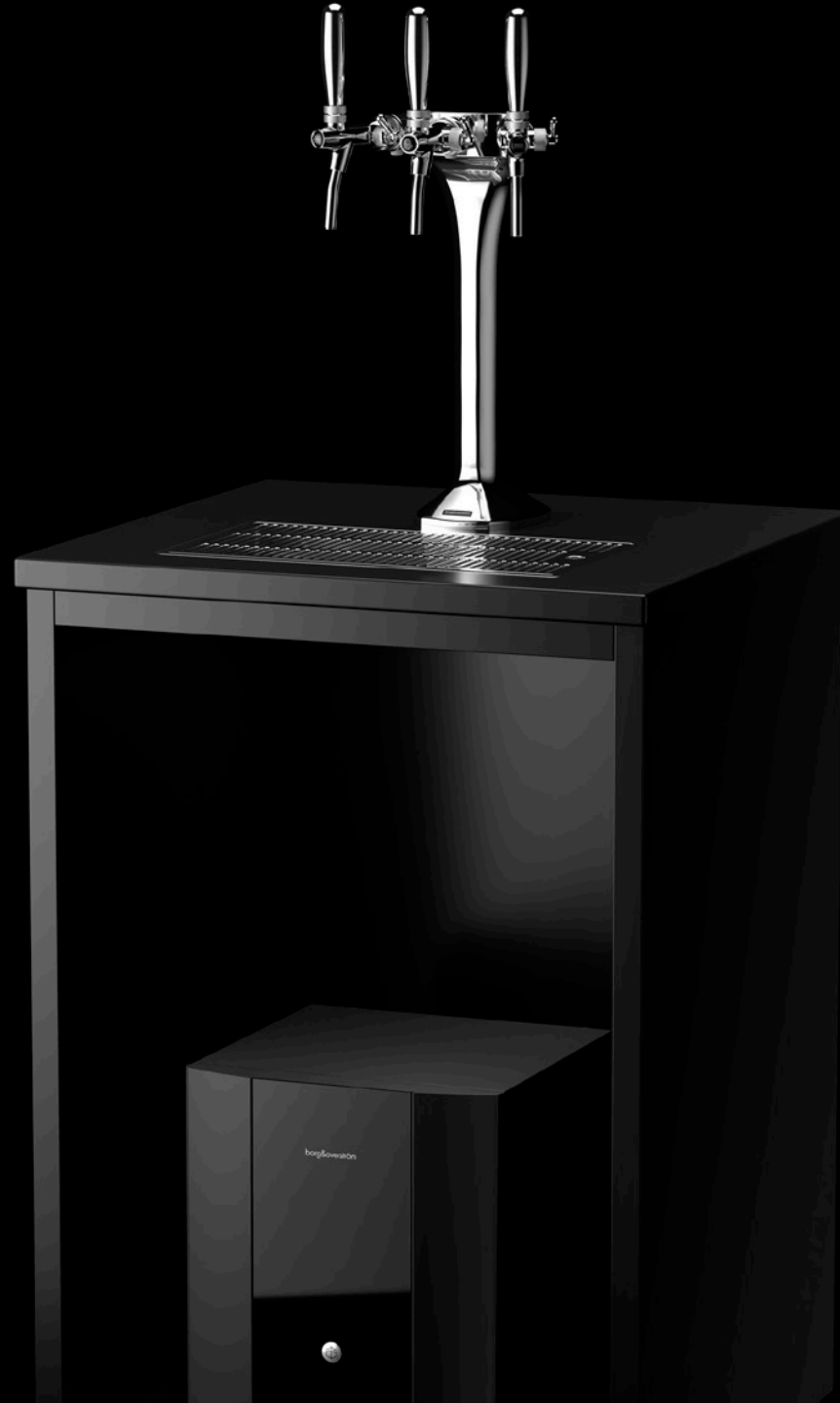

Distinctive
by design.

Fox

Water system



Dry Chill®

Configurations



Integrated Tap

Water options



Chilled



Ambient

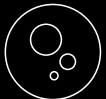

Sparkling

www.foxtrading.co.uk



borg&
overström

Distinctive
by design.

C2
C3

Distinctive
by design.

Specifications	C2 ProCore+	Dispense options	Max power consumption	Tap dimensions	Chrome	Chrome ECO-UV
Power requirements Hertz 50/Volts 230-240	Throughput flow rate 80 litres per hour (LPH) 90 500ml bottles per hour (BPH)	Chilled & Ambient	210W	W165xD230xH465mm	746000	746010
Water system Dry Chill®		Chilled & Sparkling	260W	W165xD230xH465mm	746020	746030
Chilled temperature Min 2°C/Max 11°C	C3 ProCore+	Dispense options	Max power consumption	Tap dimensions	Chrome	Chrome ECO-UV
Dispense height 285mm						
ProCore™ dimensions W320xD375xH335mm	Throughput flow rate 80 litres per hour (LPH) 90 500ml bottles per hour (BPH)					
Simple-fit Ventilation Base W322xD431xH60mm (Includes 20mm overhang)						

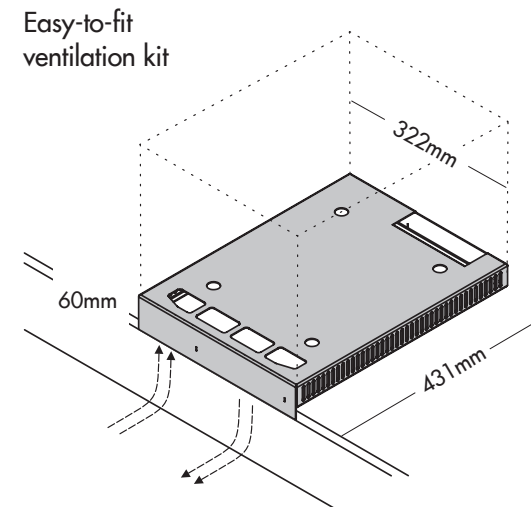

Fox

borg &
overström



Distinctive
by design.

Foxo

borg &
overström

Refined hydration, digital precision

The T2 is a next-generation digital tap system. It's bold yet practical with a premium finish. Combined with the ultra-compact ProCore™ water processing unit, the T2 integrates seamlessly into any work area or communal space.



Distinctive
by design.

t2

Refined hydration

The T2 has sleek lines, a contemporary profile, and is finished to the highest standard. With a built-in drip tray and 310mm dispense area for refilling bottles and jugs, it's also a highly practical solution for modern workplaces.

Digital precision

The discreet digital touch panel has an antimicrobial coating for a reassuringly clean experience. Chilled, sparkling, or ambient water can also be dispensed touch-free via the Bluetooth® app.

Advanced UV protection built-in

As an option, the T2 can be fitted with Viovandit™, a mercury-free, chemical-free and energy-efficient LED-UV water purification system. For complete peace of mind, it also includes additional hygiene features via Borg & Overström's Totality® methodology.

Ultra-compact, durable ProCore™

The under-counter ProCore™ system is compact, easy to install out of sight. It's also low maintenance and fitted with the new eco R290 gas. The colour-coated GreenCoat® steel construction makes it sustainable and durable.

Easy-to-fit ventilation kit

A ventilation kit is included with this system. It's easy to install and increases the efficiency of the ProCore™ by allowing a continuous cycle of cool air.

Energy-efficient

The T2 is consistently energy efficient, making it both economical and eco-friendly. It's also fitted with a low light sensor which sends the appliance into standby mode when the room is unoccupied.

Distinctive
by design.



Foxo

borg &
overström

Water system



Dry Chill®

Configurations

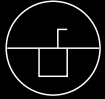

Integrated Tap

Water options



Chilled



Ambient



Sparkling

Tap finishes



Steel



Black



Distinctive
by design.

t2

Distinctive
by design.

T2 Specifications	T2 ProCore	Dispense options	Max power consumption	Black	Steel	Black ECO-UV	Steel ECO-UV							
Power requirements Hertz 50/Volts 230-240	Throughput flow rate 50 litres per hour (LPH) 60 500ml bottles per hour (BPH)	Chilled & Ambient	140W	742000	742010	742020	742030							
Water system Dry Chill®		Chilled & Sparkling	200W	742080	742090	742100	742110							
Chilled temperature Min 2°C/Max 11°C		Chilled, Ambient & Sparkling	200W	742160	742170	742180	742190							
Tap height 390mm	T2 ProCore+	Dispense options	Max power consumption	Black	Steel	Black ECO-UV	Steel ECO-UV							
Dispense height 310mm								Throughput flow rate 80 litres per hour (LPH) 90 500ml bottles per hour (BPH)	Chilled & Ambient	140W	742240	742250	742260	742270
ProCore dimensions W320xD375xH350mm								Chilled & Sparkling	200W	742320	742330	742340	742350	
Simple-fit Ventilation Base W322xD431xH60mm (Includes 20mm overhang)		Chilled, Ambient & Sparkling	200W	742400	742410	742420	742430							

Easy-to-fit
ventilation kit

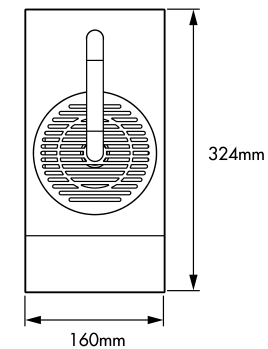
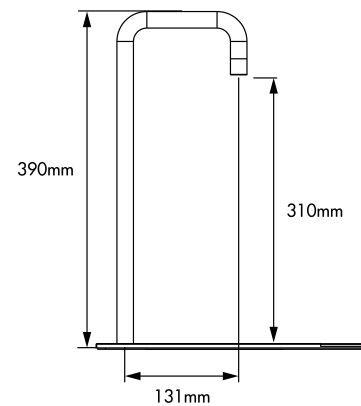
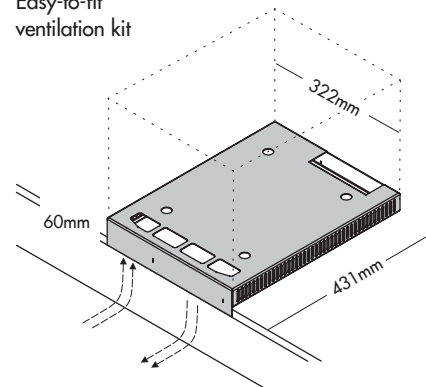



Totality® is our assurance that water dispensed from a Borg & Overström water dispenser is as safe as it is refreshing. Water dispensers with a six-star Totality® rating deliver an exceptionally high standard of hygiene.



Advanced UV-led protection.
As an option, the taps can be fitted with Viovandit™, a mercury-free, chemical-free and energy-efficient LED-UV water purification system. For complete peace of mind, it also includes additional hygiene features via Borg & Overström's Totality® methodology.



Sealed drinking water system.
Dry Chill® is the most hygienic cooling process. No water is stored within the system, which greatly reduces the opportunity for bacteria to become established. Dry Chill® also produces a larger volume of lower temperature water due to its faster recovery time.



Independently certified anti-microbial, antipathogen sanitising procedure.
All dispensers are sterilised using Sterizen® sanitising infusion. No other brand of watercooler goes through this process, which is why only Borg & Overström appliances are laboratory certified to be 99.999% bacteria reduced.



High-performing, easy to fit carbon filters.
3M carbon filters provide the highest level of water hygiene security for your dispenser over a longer period of time. All Borg & Overström water dispensers can be fitted with 3M carbon filters.



Digital precision (T2 only)
The discreet digital touch panel has an antimicrobial coating for a reassuringly clean experience. Chilled, sparkling, or ambient water can also be dispensed touch-free via the Bluetooth® app.

Distinctive by design.

Additions for C2/C3



Biodegradable paper cups
Environmentally-friendly disposable cups designed to fit Borg & Overström cup dispensers perfectly.



Personal drinking bottles
500ml capacity in black. Comes with quick-release leak-proof cap and carry strap.



500/750ml glass bottles
Suitable for dishwashers and bottlewashers. Both sizes are a perfect fit for the tap. Stylish swing-top lid.



Deep Sparkle® CO² refills
Can be disposed via standard steel recycling or general waste. Requires CO² regulator with gauge.



Sanitisation kit
Six monthly sanitising cycles ensure appliances function at the optimum hygiene levels.

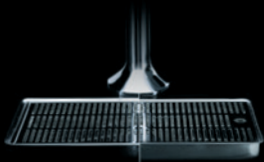

Optional drip trays (C2/C3 only). There is a range of integrated or freestanding stainless steel drip trays.



Alarmed waste kit
Featuring an audible high-water level alarm to prevent the waste tank from overflowing.



Install kit with 3M filter
Install appliances simply and effectively in a wide range of applications. Complete with a 3M filter.

Distinctive
by design.



For more details or to arrange personal demonstration of the C2/C3 and T2

Please contact us at:
www.foxtrading.co.uk/contact-us
or scan QR code below

